

# Corian® Specification Sheet : 5211L 720 Washplane

[Revised November 2019]

## Notes:

Tap hole cutouts not included, drawing for location reference only.  
All external edges sanded to 2mm radius  
Top surface sanded to semi-gloss finish

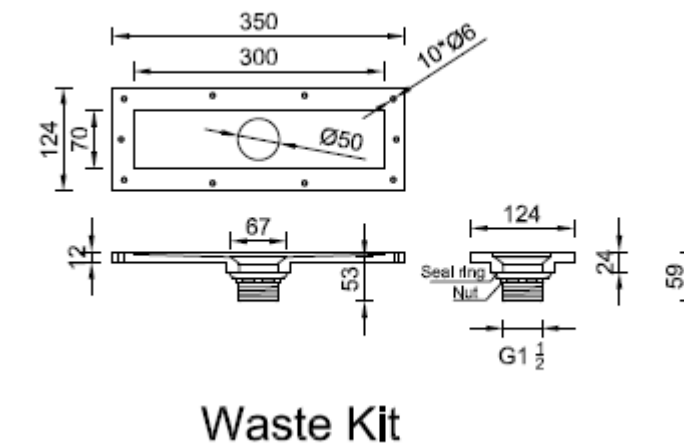
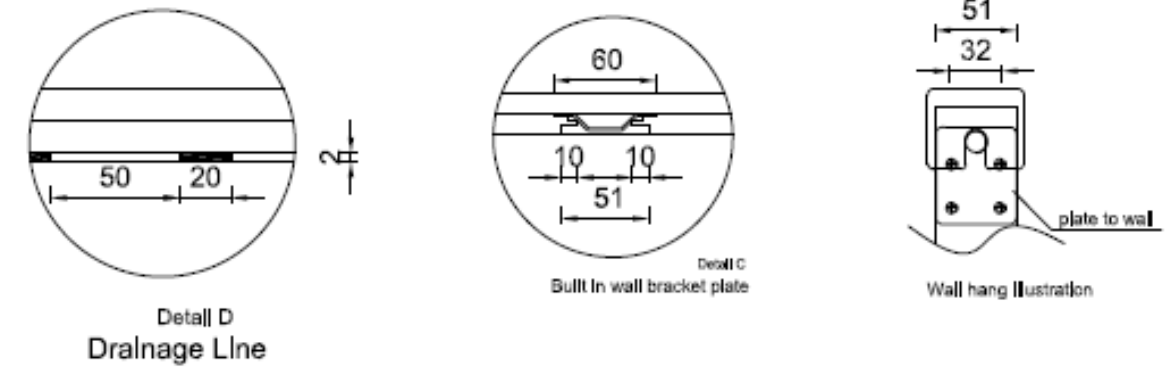
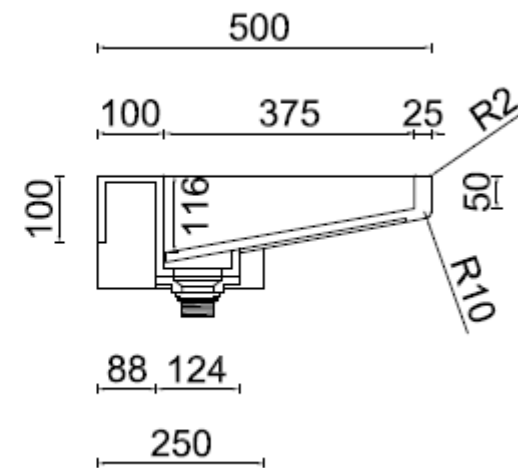
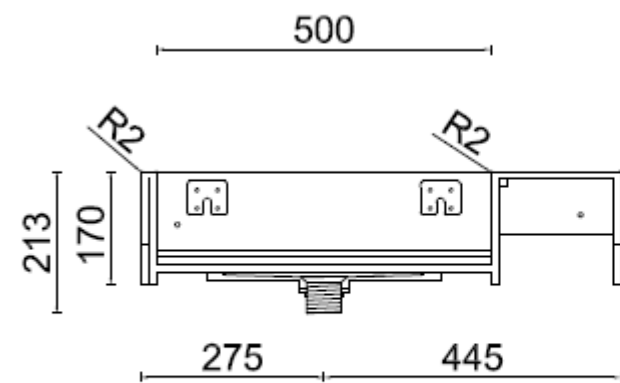
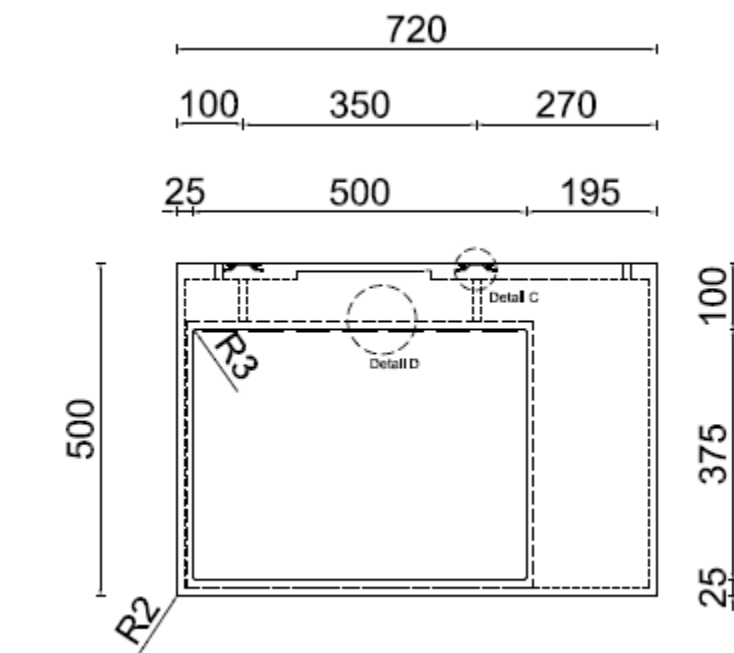

Head Office & Showroom

2/5-11 Mellor St, West Ryde NSW 2114

P: 1300 795 485 E: info@scfinteriors.com.au



6	1 plywood wall bracket template
5	2 wall bracket fixing plates & screws
4	2 M8x80 expansion bolt
3	1 waste fitting, pre-assembled to #2
2	1 Corian waste kit, pre-assembled to #1
1	1 Corian Washplane PWD 5211L 720
#	Packing List