

# Corian® Specification Sheet : 3223 Washplane

[Revised November 2019]

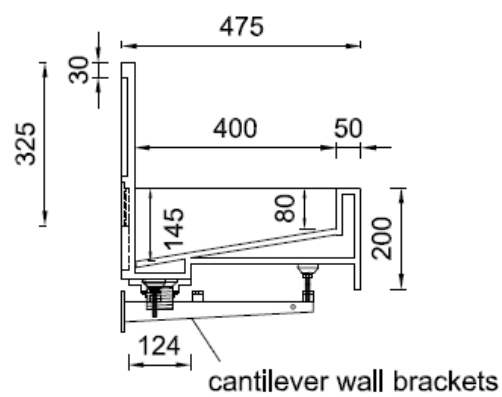
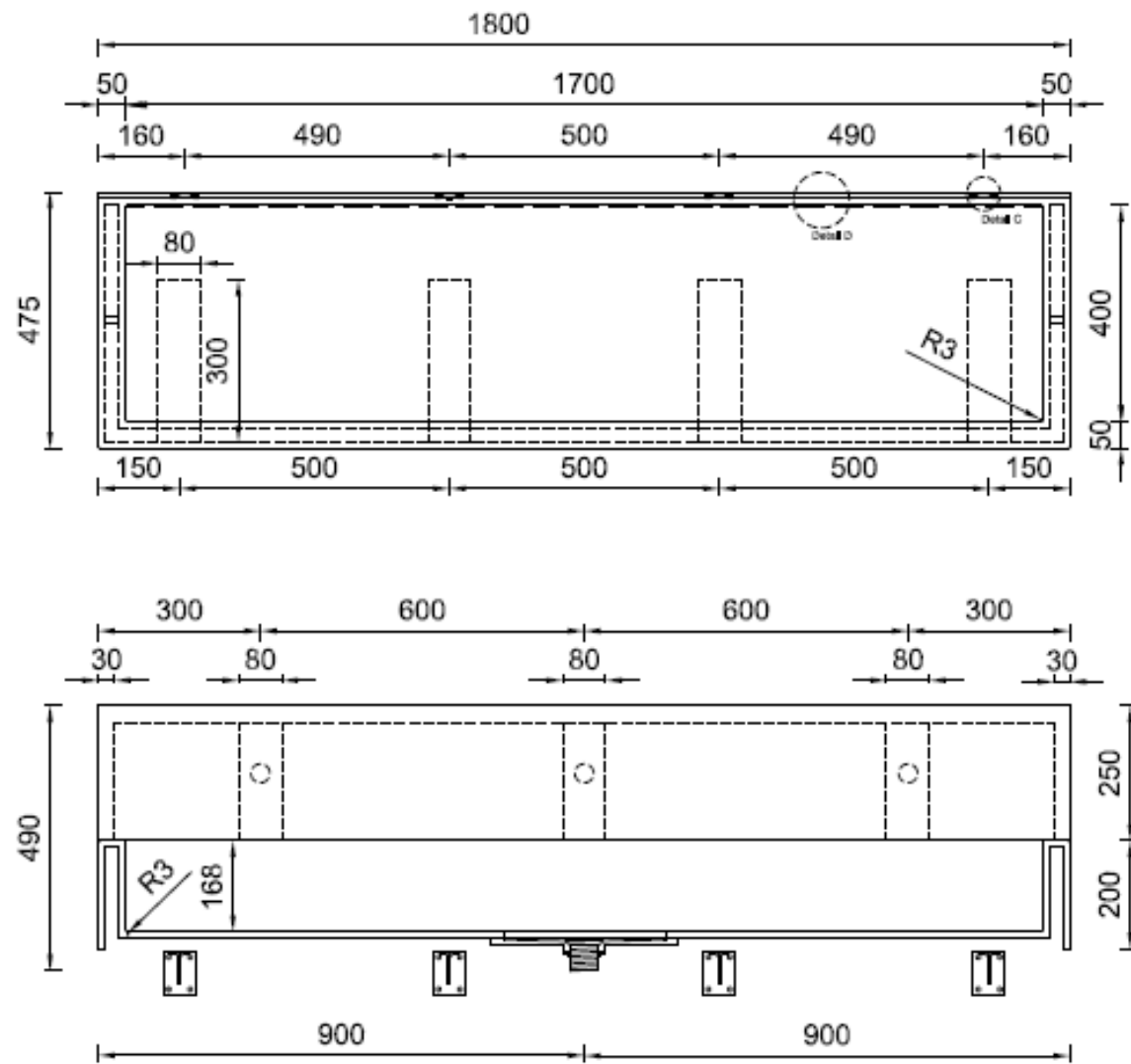

## Notes:

- Tap hole cutouts not included, drawing for location reference only.
- All external edges sanded to 2mm radius
- Top surface sanded to semi-gloss finish

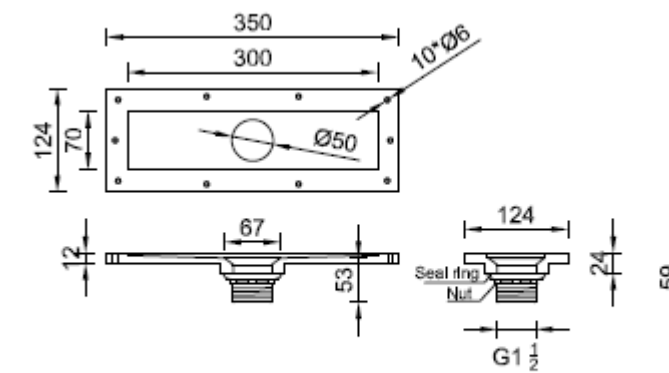
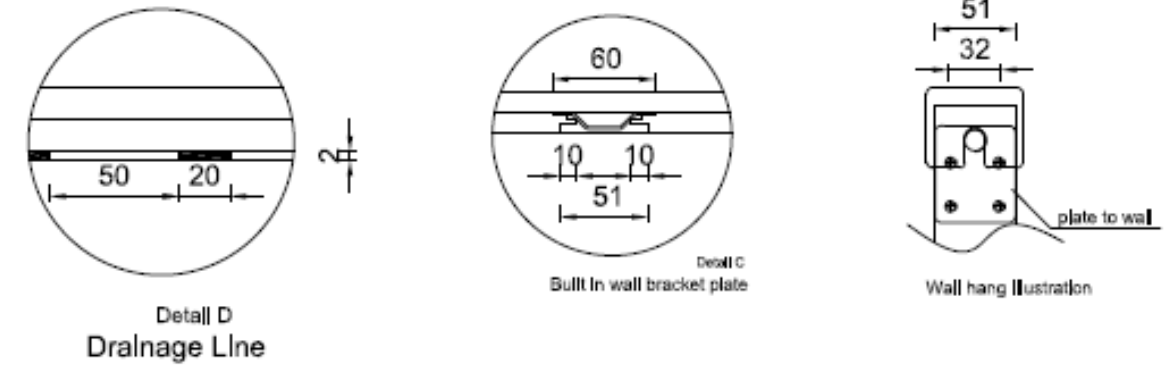

## Waste Kit

6	1 plywood wall bracket template
5	4 wall bracket fixing plates & screws
4	4 x 380mm adjustable cantilever wall brackets & screws
3	1 waste fitting, pre-assembled to #2
2	1 Corian waste kit, pre-assembled to #1
1	1 Corian Washplane 3223
#	Packing List



Head Office & Showroom

2/5-11 Mellor St, West Ryde NSW 2114  
P: 1300 795 485 E: info@scfinteriors.com.au

