

# Corian® Specification Sheet : 3145 Washplane

[Revised November 2019]

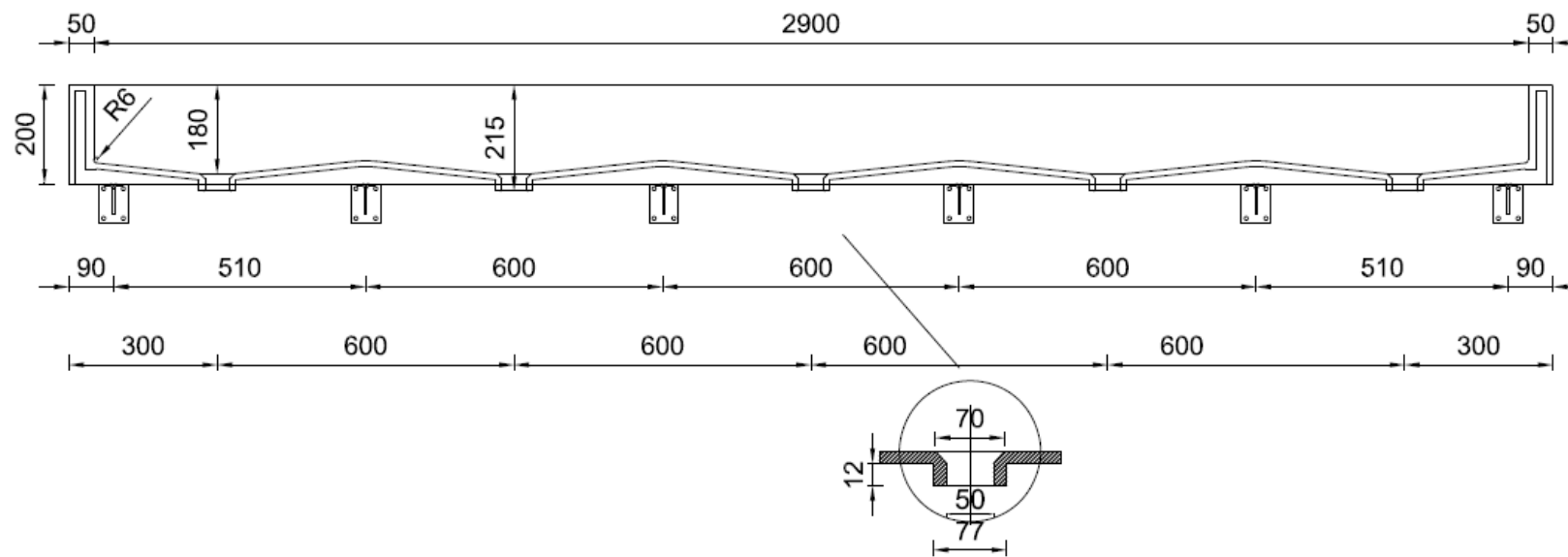
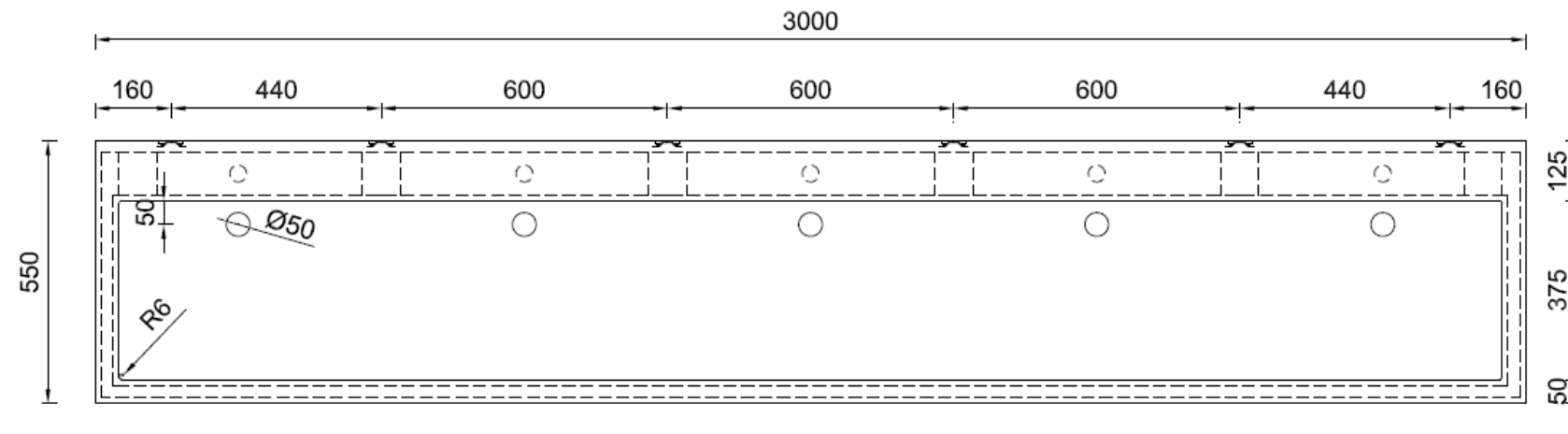

## Notes:

- Tap hole cutouts not included, drawing for location reference only.
- All external edges sanded to 2mm radius
- Top surface sanded to semi-gloss finish

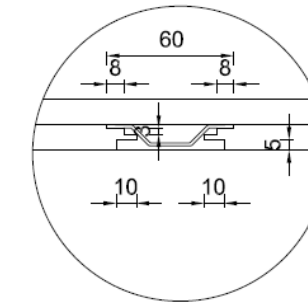

Built in wall bracket plate

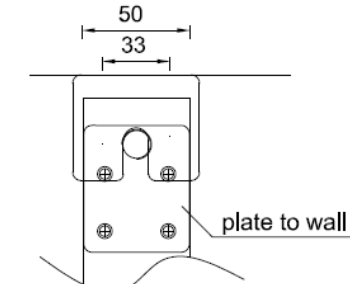

Wall hang illustration

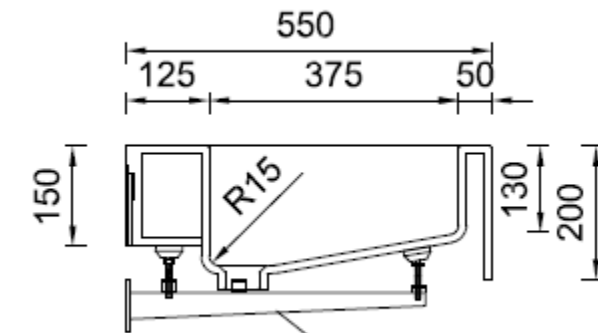

cantilever wall brackets



Head Office & Showroom

2/5-11 Mellor St, West Ryde NSW 2114

P: 1300 795 485 E: info@scfinteriors.com.au



|   |  |
|---|--|
| 6 | Installation instruction sheet                   |
| 5 | 1 plywood wall bracket template                  |
| 4 | 6 wall bracket fixing plates & screws            |
| 3 | 6 adjustable cantilever wall brackets and screws |
| 2 | 5 waste fittings                                 |
| 1 | 1 Corian Washplane 3145                          |
| # | Packing List                                     |