

Corian® Specification Sheet : 3143 Washplane

[Revised November 2019]

Notes:

- Tap hole cutouts not included, drawing for location reference only.
- All external edges sanded to 2mm radius
- Top surface sanded to semi-gloss finish

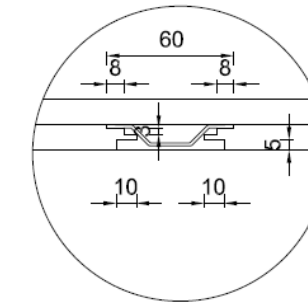
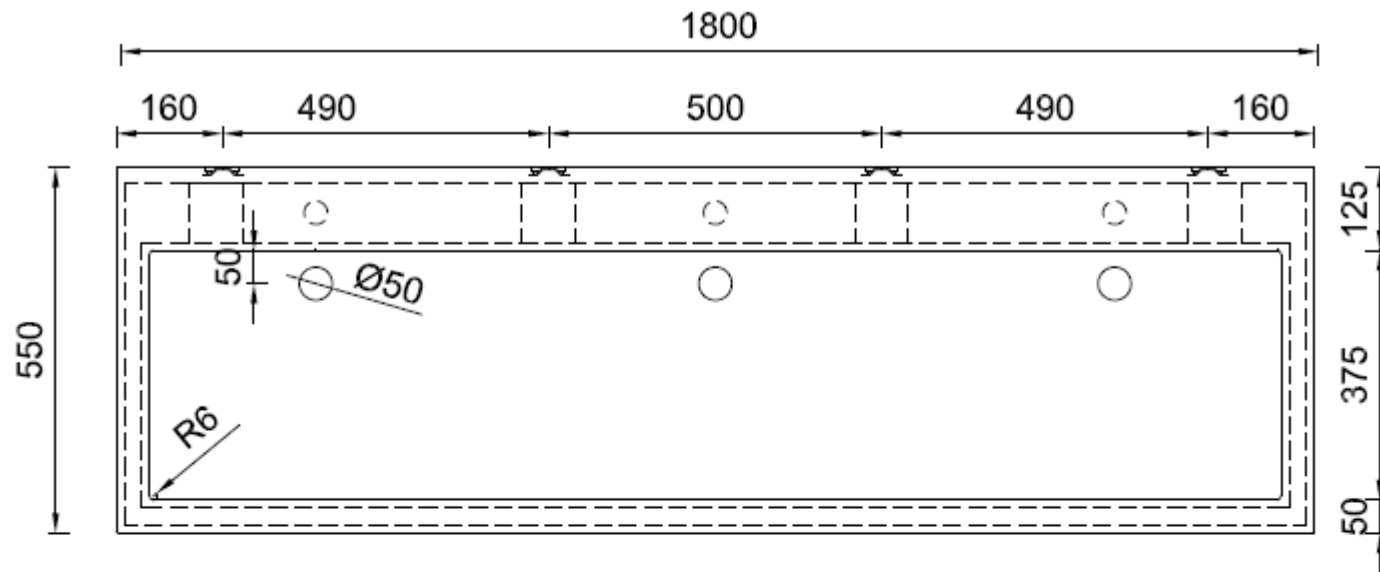

Built in wall bracket plate

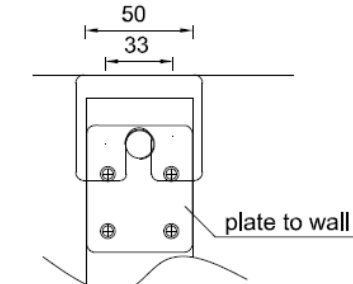

Wall hang illustration

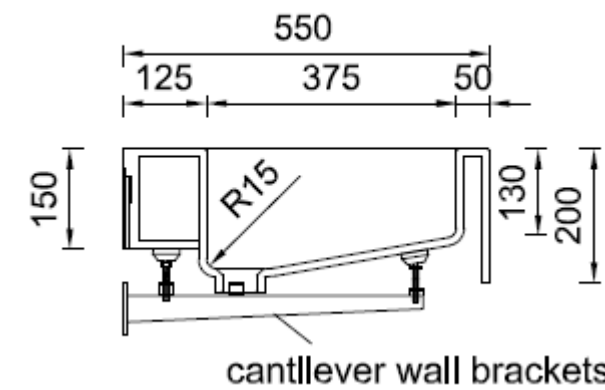
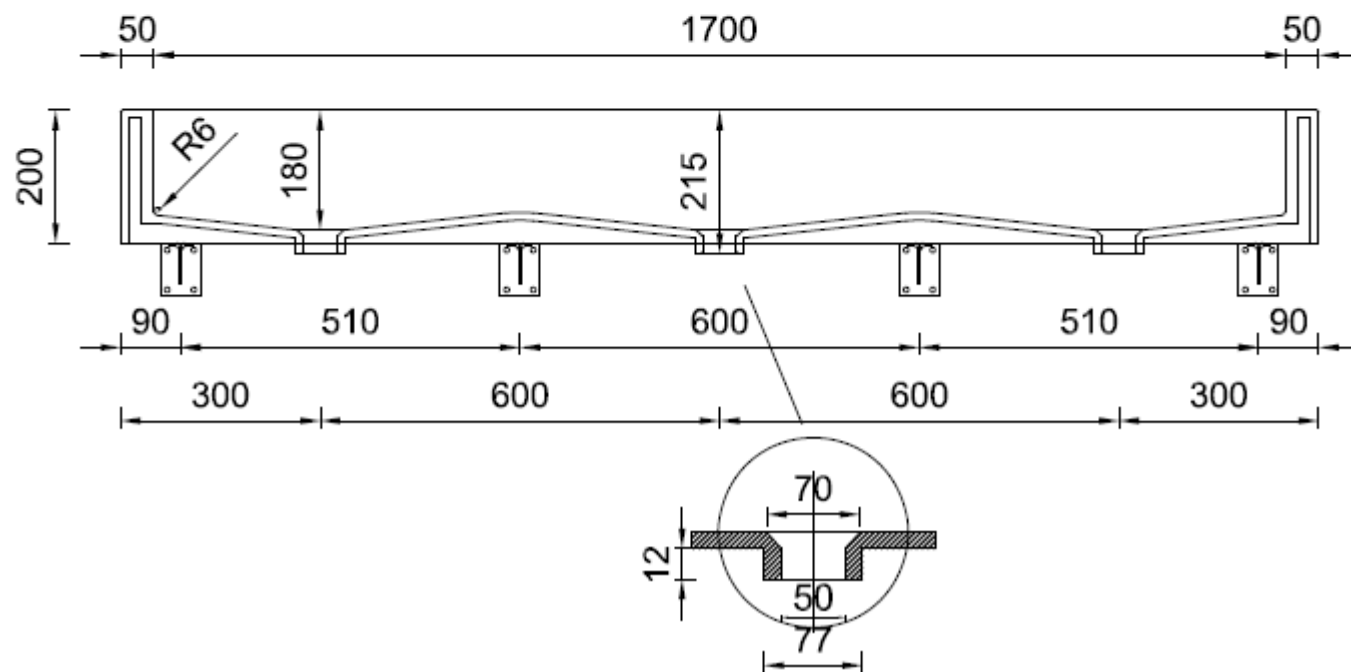

cantilever wall brackets



Head Office & Showroom

2/5-11 Mellor St, West Ryde NSW 2114
P: 1300 795 485 E: info@scfinteriors.com.au



6	Installation instruction sheet
5	1 plywood wall bracket template
4	4 wall bracket fixing plates & screws
3	4 adjustable cantilever wall brackets and screws
2	3 waste fittings
1	1 Corian Washplane 3143
#	Packing List