

# Corian® Specification Sheet : 3142 Washplane

[Revised November 2019]

## Notes:

Tap hole cutouts not included, drawing for location reference only.  
 All external edges sanded to 2mm radius  
 Top surface sanded to semi-gloss finish

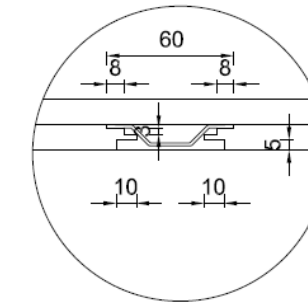
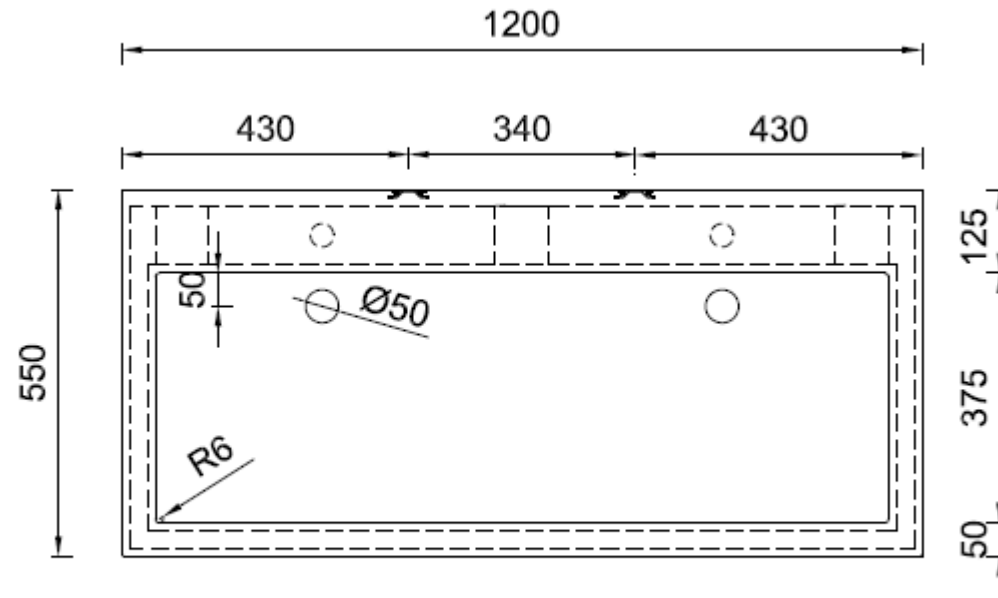

Built in wall bracket plate

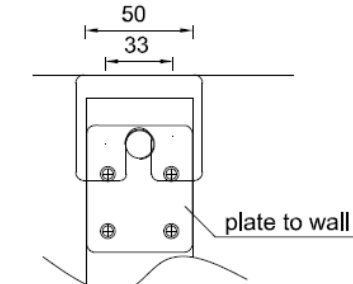

Wall hang illustration

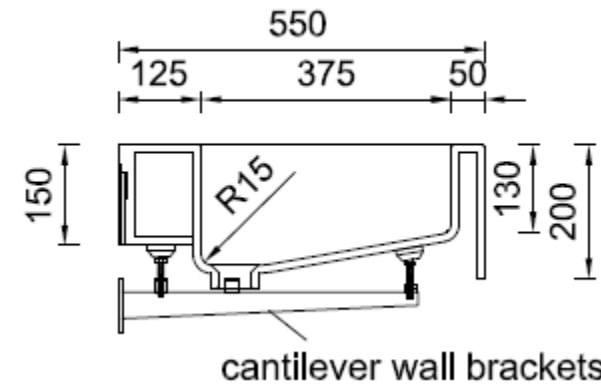
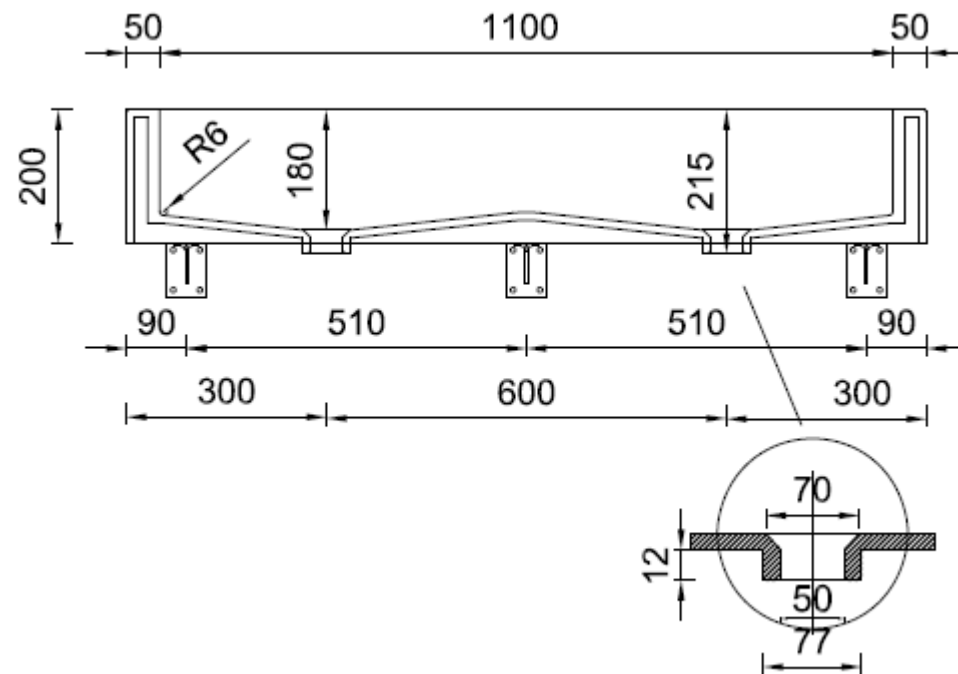

6	Installation instruction sheet
5	1 plywood wall bracket template
4	2 wall bracket fixing plates & screws
3	3 adjustable cantilever wall brackets and screws
2	2 waste fittings
1	1 Corian Washplane 3142
#	Packing List



Head Office & Showroom

2/5-11 Mellor St, West Ryde NSW 2114  
 P: 1300 795 485 E: info@scfinteriors.com.au

